

INDUSTRIAL LUMINAIRES

TLP44 MLED

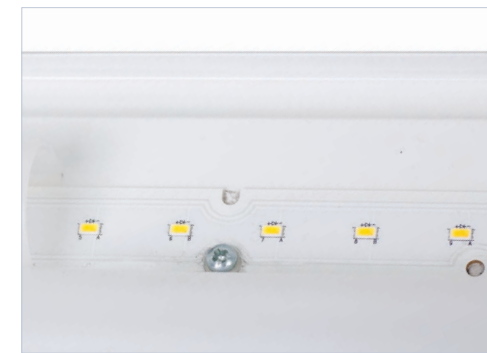

IP 67; IP 66; CLASS I



DIMENSIONS [mm]

Type	L	L1	W	H
TLP 44-MLED220	728	430	159	119
TLP 44-MLED240	1336	950	147	119

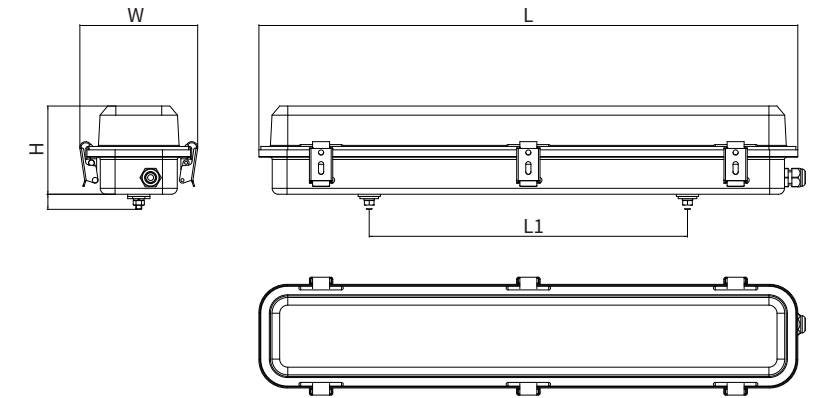

APPLICATION

Dustproof and watertight luminaire for LED source type. Designed for the industrial facilities, utility rooms: warehouses, production spaces, workshops, pathways and outdoor areas limited to spaces partially protected against the weather - ie .: sheds, roofing, etc.

For areas fully exposed to the weather conditions use dedicated stainless steel version or with WN brackets.

Luminaire equipped with diffuser mounted on LED panel for light pattern shaping and reducing glare.

TECHNICAL DATA

Protection class:	I
Protection degree:	IP 67, IP 66
Power factor:	≥ 0,95
Ambient temperature:	from -25°C to +40°C*
Power supply:	220-240V AC/DC
Lifetime:	L70/B50 for > 60 000h

*Ambient temperature with battery from 0° up to +40°C

ELECTRIC UNIT

Cable gland:	2 x M20, 2 x blanking plug
Cable diameter:	ø 6-12 mm
Terminal block:	2x/3x6 mm ²

TYPE	WATTAGE	LUMEN OUTPUT	WEIGHT
TLP 44-MLED220/211	23 W	3121 lm	4,0 kg
TLP 44-MLED240/411	46 W	5760 lm	6,5 kg

CONSTRUCTION

Housing:	zinc coated steel, powder painted
Diffuser:	UV stabilized and strengthened polycarbonate **
Diffuser clips:	stainless steel
Mounting plate:	zinc coated steel, powder painted

**Chemical resistance diagram available on manufacturer's website in section „Designers area“

31-144-9002	"W" bracket (2 pcs set)
31-153-2001	slanting bracket (2 pcs set)
31-153-2000	angular bracket (2 pcs set)
31-144-8999	eyelet sling (2 pcs set)
31-144-8997	3/2" stainless pole bracket (2 pcs set)

ADDITIONAL EQUIPMENT

Only for zinc coated steel version

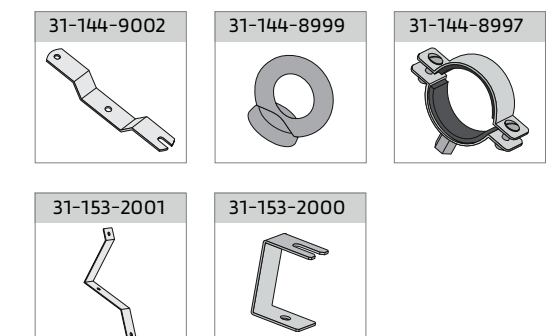

TECHNICAL DATA



APPROVALS



INDUSTRIAL LUMINAIRES

rlt.rh.pl

REMONTOWA
MEMBER OF
REMONTOWA
HOLDING S.A.
LIGHTING TECHNOLOGIES

INDUSTRIAL LUMINAIRES | available configurations

TLP44 MLED



WATTAGE	CRI AND COLOUR TEMP.	HOUSING	CABLE ENTRY	CABLE GLANDS	FIXING TYPE	OPTIONS		
220 24W	830 CRI 80 3000 K	- zinc coated steel	P 	10 M20 poliamide	W	A3 battery backup system 3h with autotest	DALI	ZT low temp. version**
240 48W	840 CRI 80 4000 K	S stainless steel 304*	PA 	11 M20 brass	WN	A3/TEMP battery backup system 3h with heater**		WT high temp. version***
	850 CRI 80 5000 K	S316 stainless steel 316L*	K 	13 M20 brass screen cable	H	CB version for central battery		
	865 CRI 80 6500 K		KA 	20 M25 poliamide				
			PAK 	21 M25 brass				
				23 M25 brass screen cable				

* please select bracket W or WN

** version without CNBOP certificate

***The parameters of the ZT and WT version are not standard.

Ask for details..

