

**DLP
91**



Type	Light source power / lamp base	Light source	Weight
DLP 91	max 50 W GU5.3	halogen lamp LED lamp	0,3 kg

Adjustable downlight, max 50W

Approvals

according to the rules of relevant classification societies, additional IEC

Housing

die - cast gold plated, chrome plated, white painted, other colours on request

Lamps (not included)

LED or halogen lamp max. 50W

Electric

12V, flexible wiring, heat resistant up to + 250°C

Connections

plug and socket /Wieland GST/

Mounting

with 2 fixing clips

Remark

electronic transformer ET -.... has to be ordered separately (not applicable to GU10)

DIMENSIONS [mm]

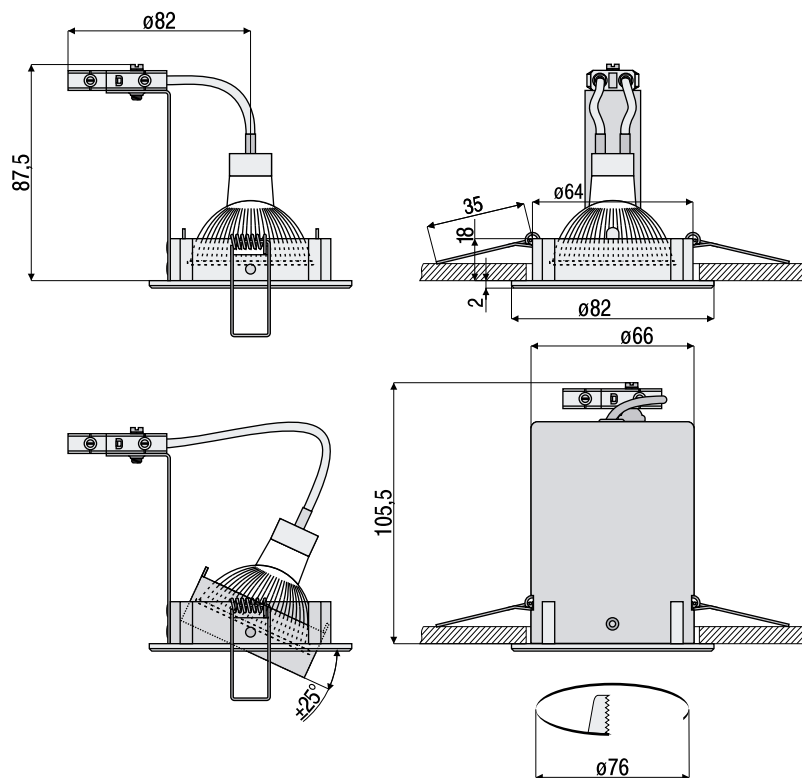

ORDER SPECIFICATION

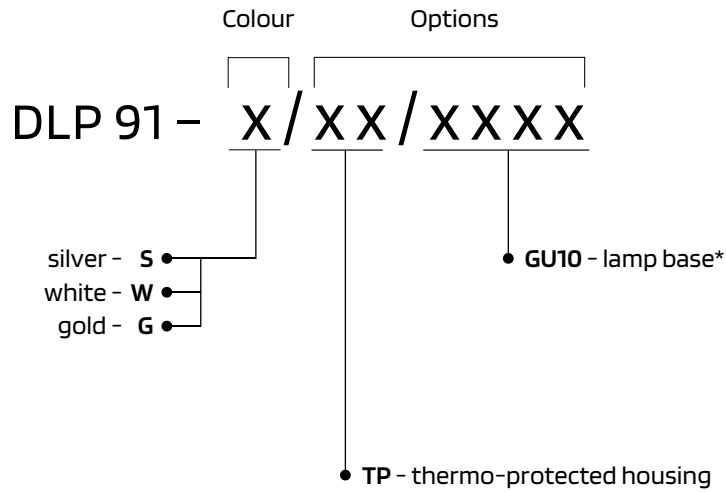

*with this option electronic transformer is not required

Example of type description

DLP 91 - S light fitting for halogen lamp max 50W with socket GU5.3; colour - silver

TECHNICAL DATA

IP 20

12V

GU 5,3



OPTIONS

Electronic Trans-
former 220V-240V
50-60Hz

Thermo-protected
Housing

GU 10

